



DESIGN NOTES

Tiny Regulators Drive White LED Backlights – Design Note 231

Dave Kim

Introduction

The emergence of color LCD displays in handheld information appliances has created the need for a small, bright white backlight. Fortunately, the recent commercialization of high intensity white LEDs provides the perfect solution. These tiny LEDs are capable of delivering ample white light without the fragility problems and costs associated with fluorescent backlights commonly used in notebook computers. However, they do pose a problem—the forward voltage of white LEDs can be as high as 4V, precluding powering them directly from a single lithium-ion cell.

This Design Note describes several different circuits that may be used to boost and regulate the Li-Ion battery voltage to power white LEDs. These circuits provide sufficient power to drive multiple white LEDs and are small enough to easily fit within cellular telephones and handheld computers.

Circuit Descriptions

Figure 1 depicts a very small charge pump DC/DC converter that is capable of powering four white LEDs at 15mA each (the typical forward current used for backlighting). The LTC[®]1754-5 used in this application is a tiny SOT-23 device that delivers a regulated 5V output without any inductors. The entire circuit occupies less than 0.1 in² of board space (excluding the LEDs) and may be powered directly from a lithium-ion cell.

A constant-current backlight supply may be constructed using the LTC1682. This architecture has several advantages: first, it directly controls the LED current regardless of the forward voltage drop across the LED. Additionally, the LTC1682's output is regulated by an on-chip linear regulator to deliver a very low noise output to the LEDs. Output ripple is less than 4mV and eliminates the risk of RF interference in sensitive cellular phone applications. The LTC1682's high current output is capable of powering five parallel LEDs at 15mA each from a single lithium-ion cell.

Applications requiring more white LEDs or higher efficiency can use an LT[®]1615 boost converter to drive a series connected string of LEDs. The high efficiency circuit shown in Figure 3 can provide a constant-current drive for up to eight LEDs. Driving eight white LEDs in series requires approximately 29V at the output and is possible due to the internal 36V, 350mA switch in the

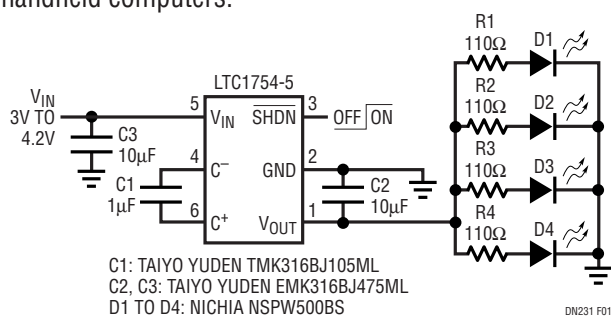

Figure 1. LTC1754 White LED Driver

LT, LTC and LT are registered trademarks of Linear Technology Corporation.

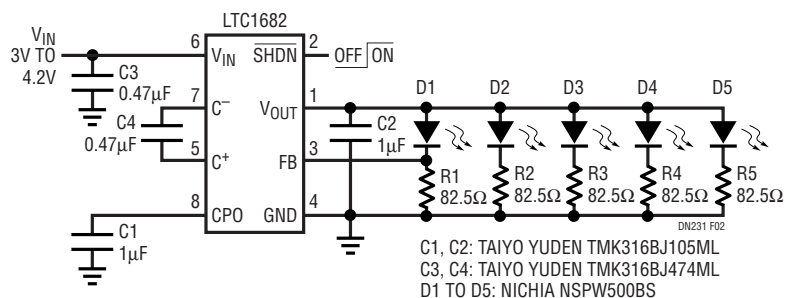

Figure 2. LTC1682 Low Noise White LED Driver

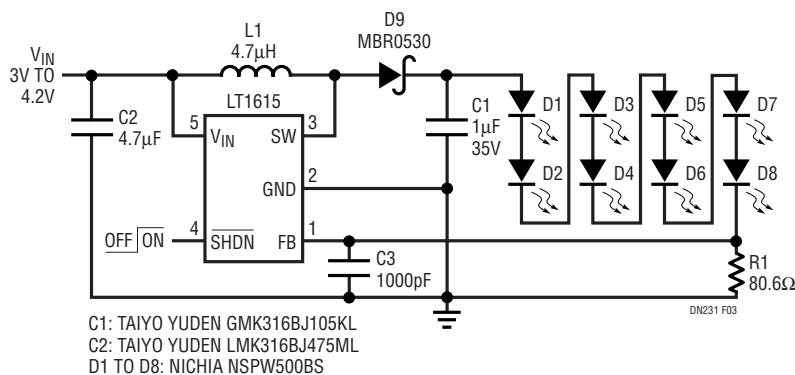

Figure 3. LT1615 White LED Driver

LT1615. The constant-current design of the circuit guarantees the same LED current through all series LEDs, regardless of the forward voltage differences between the LEDs. Although this circuit is designed to operate from a single Li-Ion battery (2.5V to 4.2V), the LT1615 is also capable of operating from inputs as low as 1V with commensurate output power reductions.

Brightness Control

The brightness of the LED can be controlled by applying a PWM signal to the SHDN pin on any of the backlight circuits shown as long as a couple of precautions are taken. Because of the “soft-start” circuitry incorporated in these DC/DC converters, the output voltage will not immediately rise to full output after the SHDN pin is taken high. Consequently, a PWM signal in the range of 200Hz is recommended—much faster and brightness control will be nonlinear; much slower and flicker may be observed. It may also be desirable to place a resistor between the DC/DC converter output and ground (in parallel with the LED load) to discharge the output during shutdown. Select a resistor that will draw approximately 1mA when the DC/DC converter is operational. (A parallel resistor is not required with the LTC1682 because it contains internal discharge circuitry.)

As an alternative to using PWM control, a DAC output can also be used to control the brightness of the LEDs in

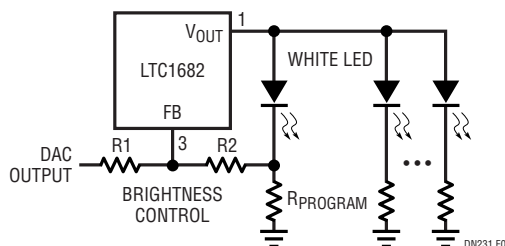

Figure 4. Brightness Control Using DAC Output

Figures 2 and 3. As depicted in Figure 4, the DAC output controls the brightness of the LED by varying the voltage across $R_{PROGRAM}$. Since the regulator holds the feedback voltage constant, varying the DAC voltage will affect the current flowing through the LEDs. A lower DAC voltage will result in higher brightness, while a high DAC voltage will result in lower brightness.

Summary

The circuits shown are several examples of very tiny step-up regulators that are suitable for driving white LEDs. These circuits contain such desirable features as constant-current LED drive, low noise (important for cellular telephone applications), brightness control and low voltage input (LT1615). Consult Linear Technology for additional applications assistance with white LED circuits.

Data Sheet Download

<http://www.linear-tech.com/go/dnLTC1754>
<http://www.linear-tech.com/go/dnLT1615>
<http://www.linear-tech.com/go/dnLTC1682>

For literature on our Charge Pumps, call **1-800-4-LINEAR**. For applications help, call (408) 432-1900, Ext. 2681